

LUCAS

**SERVICE TRAINING
CENTRE**

**Petrol Injection
Mk II**



LUCAS

SERVICE TRAINING CENTRE

PETROL INJECTION MARK II



JOSEPH LUCAS (SALES & SERVICE) LTD · BIRMINGHAM B18 6AU

CONTENTS

	Page(s)
INTRODUCTION	5
PART 1 DESCRIPTION AND FUNCTION OF PETROL INJECTION SYSTEM	7 - 12
Filter Units	7 - 8
Fuel Pump	8
Pressure Relief Valve	9
Metering Distributor/Control Unit	9
Principles of Shuttle Metering	9 - 10
Function of Metering Distributor	10
Function of Mixture Control Unit	11
Injectors	12
Fault Diagnosis: Preliminary Checks	12
Test Equipment	13
Faults in the Petrol Injection System	13 - 14
Fuel Pump Tests: Results and Conclusions	15 - 16
PART 2 WORKSHOP INSTRUCTIONS	17 - 30
Exploded View of Metering Distributor and Mixture Control Unit	18
Dismantling and Reassembly of Metering Distributor/Control Unit	20 - 22
Setting Datum Track Angle	22 - 23
Bench Testing: Test Specifications	24 - 25
Alternative Testing Procedure	25 - 26
Effects on Performance: Adjusting Calibration Screws	26
Dismantling and Servicing Fuel Pump and Motor	27 - 28
Fitting Unions on Fuel Injection Pipes	29
Bench Testing Relief Valve	29
Bench Testing Pump and Motor Unit	29 - 30
Bench Testing Injectors	30
How to Inhibit a Car Fitted with Lucas 'PI' Equipment	30
Diagrams of Petrol Injection Systems:	
2.5 (Early cars)	31
2.5 (Later cars)	31
2.5 Estate Car	32
TR Sports Car	32

© Joseph Lucas (Sales & Service) Ltd., 1971

JOSEPH LUCAS (SALES & SERVICE) LTD., BIRMINGHAM B18 6AU, ENGLAND

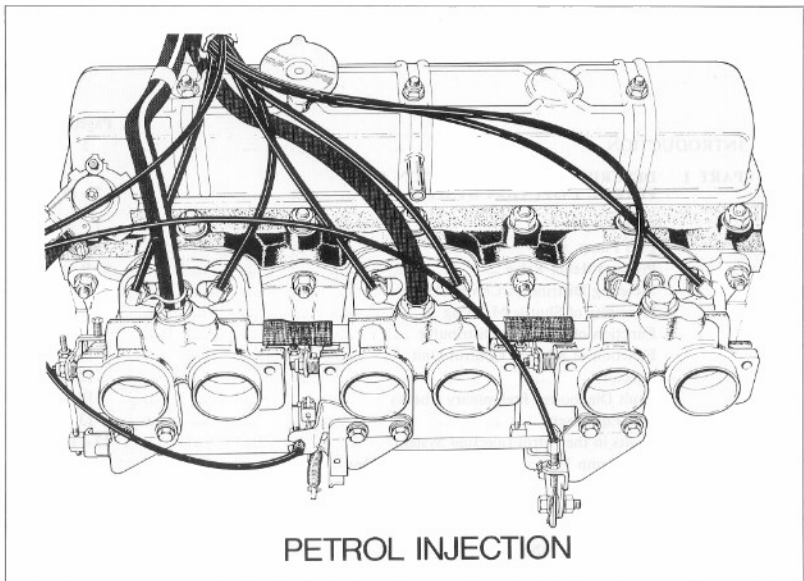

Fig. 1

INTRODUCTION

The Lucas Mark I petrol injection system has been outstandingly successful on high performance cars, particularly in the international racing field.

During 1966-67 the first three places in almost every Grand Prix event were held by cars equipped with a Lucas Mark I petrol injection system. Since 1967 practically all racing cars have used Lucas petrol injection.

The Mark II petrol injection system has been evolved directly from the Mark I system, and is designed for production cars, being supplied as original equipment on certain of the latest cars (Triumph market a 2.5 litre saloon, and their 'TR' sports car with petrol injection). The Mark II 'P.I.' system is suitable for engines developing up to 150 b.h.p., and is engineered to extremely fine limits. Although a simplified design compared to the Mark I equipment, it retains all the essential features which have been proved on the racing circuits of the world.

The conventional carburettor is not required in the petrol injection system. Instead fuel is injected into each air-intake port by means of a high-pressure shuttle-metering device. The comparatively simple design of the Mark II equipment ensures easy servicing if this should be necessary at any time.

Some of the more important advantages to be obtained from the use of petrol injection are:

1. **Reduced Fuel Consumption**

A more economic use of fuel, because the quantity injected into the cylinders is closely regulated to suit the engine operating conditions.

2. **Smoother Running at Low Engine Speeds, and Better Acceleration**

Engines fitted with 'P.I.' equipment accelerate quicker and have greater flexibility, particularly at low engine speeds.

3. **Increased Performance**

A complicated manifold is not required, so that the air intake is greater than normal. This ensures improved volumetric efficiency and hence increased power.

4. **Cleaner Exhaust Emission**

As there is almost complete combustion in the cylinders, the amount of unburnt hydrocarbons and carbon-monoxide is reduced. The result is 'cleaner' exhaust emission.

General Description of Petrol Injection System

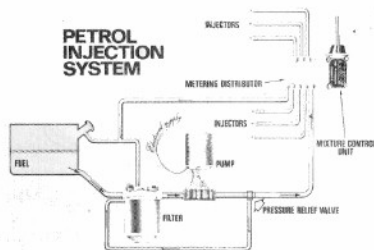

Fig. 2

Figure 2 shows the main components in the Lucas Mark II petrol injection system. Fuel from a gravity-feed tank maintains the level of fuel in the filter. The pump together with the pressure relief valve draws fuel from the filter and maintains the fuel pressure in the supply line at 100–110 lb/in^2 (689.50–758.50 kN/m^2). (Depending on installation, the valve returns excess fuel either to the filter or the petrol tank.)

Pressurised fuel is supplied to the metering distributor, which is driven from a suitable engine take-off point. Fuel charges are delivered to each cylinder in turn, by means of the injectors. The amount of fuel in these charges is varied to suit the engine requirements by means of the mixture control unit, which forms a composite unit with the metering distributor.

Components of the Petrol Injection System

FILTER UNIT

Fine particles of abrasive matter and water are often carried in suspension in the fuel. If these were allowed to pass into the system, they would cause excessive wear or corrode the precision-finished surfaces of the metering distributor and pump etc., resulting in poor engine performance and loss of power. The petrol must be filtered before entering into the system.

This is done by passing it through a special filter unit, the filter of which consists of paper strips, wound about a cylindrical core. These paper strips are cemented together, top and bottom, so as to form a series of V-shaped coils. The element provides a large filter area (approx. 550 sq. in.).

Filter Units (Sectioned) Diagrams

Figure 3 shows the three main components of the simple filter unit.

1. The filter head, made of cast aluminium. The head incorporates all fuel connections (inlet and outlet).
2. The base, made of cast aluminium, with centre stud (to accept the centre bolt of the filter head).
3. The sedimenter element, enclosed in a metal container.

The three components of the filter are held together by means of the centre bolt, which screws into the centre stud, one end of which is screwed in the base.

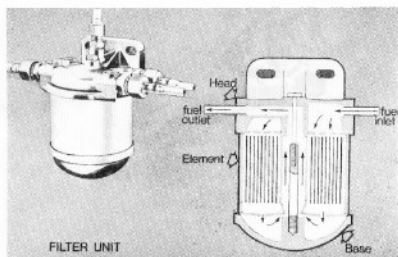

Fig. 3

FILTER

Operating Principles

Petrol from the fuel tank enters the filter unit through the inlet. It then passes through the filter element into the base, and upwards through the centre tube, leaving the filter unit by means of the outlet. Abrasive particles are retained by the filter element. In the latest type of agglomerator-sedimenter (Figure 4), droplets of water, which are forced through the pores of the filter-agglomerator medium, collect together and form large drops. These are then separated by sedimentation and accumulate in the base of the transparent housing. The level in the filter-agglomerator unit must not be allowed to rise above the base of the element.

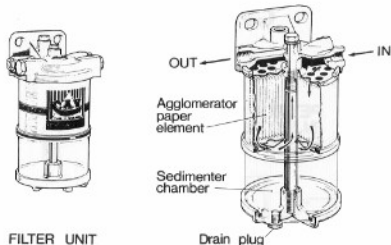

Fig. 4

FUEL PUMP UNIT

The fuel pump (Figure 5) consists of two main parts, an electric motor and a twin-gear pump.

ELECTRIC MOTOR

The electric motor which drives the fuel pump is a 12 volt high performance permanent magnet machine. The drive is transmitted to the pump gears by means of a nylon coupling.

PUMP

After passing through the filter unit, fuel enters the pump by means of the inlet. (To prevent dirt from entering the system, when the fuel pipes are removed, there is a nylon gauge strainer fitted in the pump inlet). The two spur-type gears are rotated by the action of the electric motor. As the gears rotate, fuel is expelled through the pump outlet at a pressure depending on the setting of the relief valve, normally 106 lbf/in^2 (7300 kN/m^2).

There are four sealing units in the fuel pump. A small shaft seal prevents the entry of fuel into the electric motor. The sealing properties are maintained by means of fuel, which is directed on it by the nylon coupling. (A "tell-tale" pipe in the motor end bracket indicates whether the fuel has passed this seal.)

Leakage of fuel from the pump is prevented by three sealing rings, one between the pump body and the end bracket of the motor, and the other two between the individual plates of the pump body.

In spite of its compact size, the fuel pump (Figure 5) is very powerful, and is capable of delivering a minimum of 16 gallons per hour at 100 lbf/in^2 (689.50 kN/m^2) with a current consumption of approx. 5A. The pump must have sufficient capacity to supply the extra fuel required during starting. Researches have shown that three times the normal amount of fuel may be required at 0°F (-17.7°C) to ensure a reasonably rapid start.

Note: If for any reason the fuel pump is removed from the engine, it must be replaced in the same position as originally fitted.

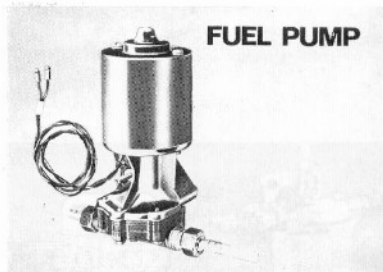

Fig. 5

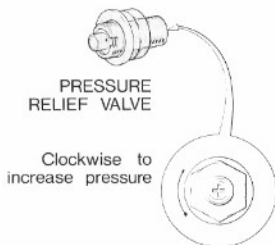

Fig. 6

METERING DISTRIBUTOR / CONTROL UNIT

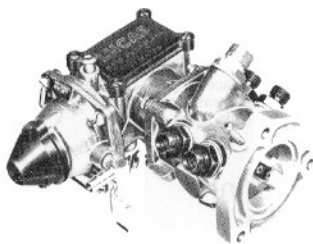

Fig. 7

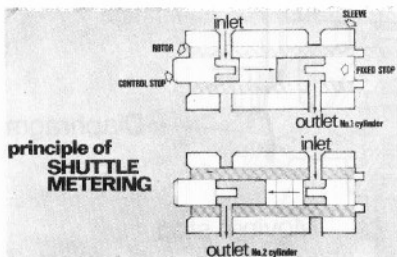

Fig. 8

PRESSURE RELIEF VALVE

The pressure relief valve maintains the pressure in the supply line at 100–110 lb/in^2 (689.50–758.5 kN/m^2) by returning excess fuel to the filter inlet. The fuel pressure is increased by turning the screw slot in a clockwise direction. If the screw slot is turned in an anti-clockwise direction, the pressure is decreased (see Figure 6).

The pressure relief valve is normally mounted in the supply line, between the pump and distributor.

METERING DISTRIBUTOR/CONTROL UNIT

The amount of fuel in each injection, and the frequency of the injections, is controlled by the metering distributor and mixture control unit (Figure 7).

The mixture control unit regulates the amount of fuel in each injection, in accordance with the requirements of the engine. The function of the metering distributor is to inject fuel into each individual inlet by a system of shuttle-metering.

The two component parts – the metering distributor and the mixture control unit – are a “matched” pair.

A faulty metering distributor or mixture control unit should be renewed, and the complete assembly recalibrated.

PRINCIPLES OF SHUTTLE-METERING

Before considering the design features of the metering distributor, it will probably be advantageous to discuss the principles of shuttle-metering. Figure 8 shows a metering distributor for a twin cylinder engine. It consists essentially of two parts; the rotor and the sleeve. The rotor has two radial ports, which lead to a centre bore containing a shuttle – which is movable between two stops (one fixed and the other adjustable). The sleeve has fuel inlet and outlet ports. The rotor fits inside the sleeve and is connected to, and driven by, the engine.

As the rotor turns, the port at the control stop end of the rotor becomes coincident with the fuel inlet port in the sleeve (see Figure 8, top diagram).

Pressurised fuel then enters the bore and drives the shuttle towards the fixed stop. This causes fuel to be discharged through the ports in the rotor and sleeve at the fixed stop end, and hence into the first cylinder through the appropriate injector.

The lower diagram shows the result of turning the rotor through 180°. Fuel now enters the bore through the port at the fixed stop end of the rotor, driving the shuttle towards the control stop. An identical amount of fuel is then delivered to the second cylinder.

(Continued)

PRINCIPLES OF SHUTTLE-METERING

(Continued)

As the rotor turns, the pressurised fuel drives the shuttle between the two stops, ensuring that an accurately metered quantity of fuel is injected into the appropriate cylinder at the right time. The low mass of the shuttle ensures a rapid response at high engine speeds.

The quantity of fuel injected is the product of the surface area of the shuttle end face and its length of travel. The length of travel is determined by the position of the control stop. The metering distributor shown is for two-cylinder engines. However, the same principles of shuttle-metering can be adapted for four, six and eight cylinder engines, by altering the position and the number of ports in the rotor and sleeve assemblies.

DESCRIPTION AND FUNCTION OF METERING DISTRIBUTOR

A metering distributor is shown in Figure 9. The rotor and sleeve assembly is made of steel and is supported inside the aluminium body by two 'O' type seals. The body has an inlet and six outlets. Fuel in the supply line is maintained at a pressure of 100-110 lbf/in² (689.50-758.50 kN/m²) by the action of the pump and the relief valve. Pressurised fuel enters the body

through the nylon gauge strainer in the inlet. The space between the sleeve, the aluminium body and the two 'O' rings is filled with fuel at pressure 100-110 lbf/in² (689.50-758.50 kN/m²). As the rotor turns, one of the inlet ports in the sleeve coincides with an inlet port in the rotor. Pressurised fuel then enters the centre bore in the rotor.

When the rotor turns through a further 60°, another inlet port in the sleeve coincides with an inlet port in the rotor. Pressurised fuel again enters the centre bore of the rotor, driving the shuttle towards the other stop. An identical amount of fuel is then delivered to the second cylinder by means of the appropriate outlet and its associated injector.

Every time the rotor completes a revolution, accurately metered quantities of fuel are delivered to each cylinder in turn, by means of the appropriate outlet. There are six outlets (on the Triumph 'PI' systems), one for each cylinder. All the outlets incorporate rubber 'O' type seals, to seal the pressurised fuel in the space between the sleeve and the rotor.

The six outlet unions locate the sleeve in the aluminium body. Leakage fuel is collected in a chamber at the drive end, and is conveyed back to the fuel tank. A small quantity of the leakage fuel is used to lubricate the rubbing surface of the cam follower. It also lubricates the Oldham type coupling, which drives the rotor at half engine-speed.

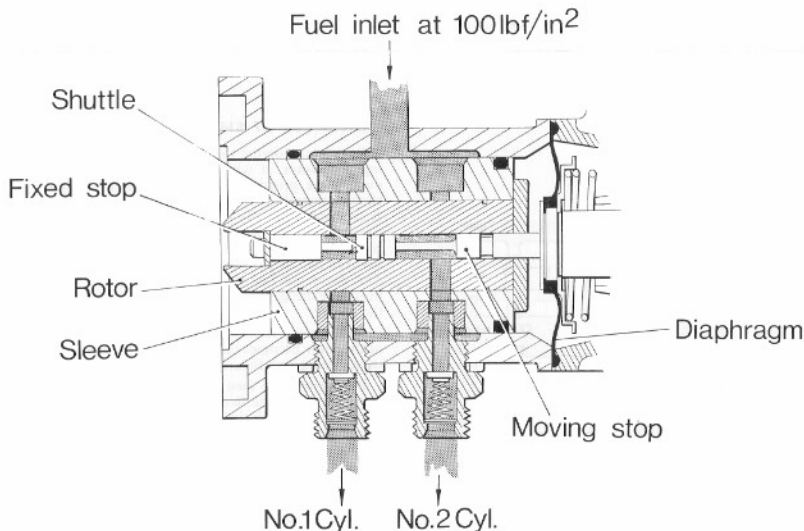

Fig. 9

DESCRIPTION AND FUNCTION OF MIXTURE CONTROL UNIT

Figure 10 shows a mixture control unit, which controls the amount of fuel in accordance with the engine requirements, by altering the position of the control stop, and hence varying the length of shuttle travel. The control stop in the metering device is kept in contact with the cam follower by means of the fuel pressure in the rotor. The balance spring, around the cam follower, counteracts the effect of this pressure, and prevents the control mechanism from being overloaded.

The control mechanism consists of a diaphragm, two links, two control springs, a fuel cam and a cam follower. The two control links are attached to the centre of the diaphragm by means of a special bearing. Any axial deflections of the diaphragm cause the links to move axially. The roller (attached to the links) moves in sympathy with them, and at the same time maintains contact with the tapered lever (or datum track) and the control stop plunger (or cam follower).

The diaphragm is mounted in a depression chamber at the end of the mixture control unit. The depression chamber is connected to the inlet manifold downstream of the throttle butterflies. Any variation in

manifold depression causes the diaphragm to deflect against the action of two control springs.

When there is full load on the engine, and the throttle is open, the diaphragm is held in the rest position by spring pressure. As the engine load is reduced, and the throttle is closed, the increased vacuum causes the diaphragm to deflect. The control links and rollers are then moved into a new position. The control stop is also moved, causing reduced shuttle-travel, and there is, consequently, less fuel in each charge.

The mixture control unit incorporates an excess fuel device, which ensures that extra fuel is supplied during starting. A wire control on the fascia panel is connected to the overfuel lever on the side of the mixture control unit. (This wire control is similar to the choke control cable used with conventional engines).

When starting the engine, the driver obtains the extra fuel by pulling out this wire control. This alters the position of the overfuel lever, and the carrier for the fuel cam is drawn away from the cam follower. The shuttle then has a longer travel. As soon as the driver pushes back the wire control, the carrier is returned to the normal operating position by the action of the tension spring.

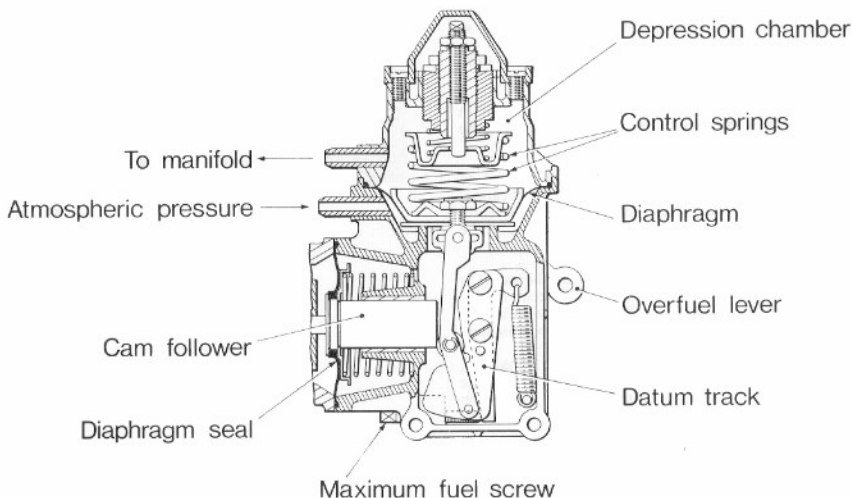

Fig. 10

INJECTORS

The fuel is injected into the engine cylinders by means of injectors of the forward opening poppet-valve type.

Figure 11 shows the main features of the injector. Fuel enters the injector at the top. The nozzle valve is kept closed by spring pressure. The valve is designed to open at 50 lbf/in² (344.73 kN/m²). The correct amount of fuel, in the form of a fine spray, is injected into the inlet manifold where it combines with the air, drawn in by the engine.

The timing of the metering unit to the engine is set in accordance with the engine designers' requirements.

The injector is not adjustable in service. However, there is only one fault likely to occur. Impurities in the fuel may become trapped on the valve seat, and thus prevent the nozzle valve from closing. These impurities can usually be removed by connecting the injector to a filtered air-supply, having a pressure of about 80 lbf/in² (551.50 kN/m²) in the forward direction. If, however, the injector remains "stuck open", it should be renewed.

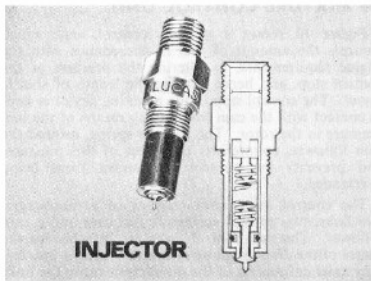

Fig. 11

FAULT DIAGNOSIS: PRELIMINARY CHECKS

If the petrol injection system is suspected of not functioning correctly, the following preliminary checks should be carried out, as a failure in any of these would give the impression that the petrol injection system was faulty.

1. Battery

Check that the battery is at least 70% charged and in good condition. If the battery is not satisfactorily charged, re-charge from an external source, as necessary.

Note: A battery in poor condition will cause difficult starting.

2. Ignition System

Faults in the ignition system can often result in symptoms similar to those caused by a fault in the fuel system. Check both LT and HT circuits.

3. Petrol Tank Breather

The petrol tank breather must be inspected to ensure the tank can breathe properly. If air cannot enter the tank, a depression will be formed. Eventually no fuel will be drawn from the tank, and the engine will stop.

4. Back Leakage Return to Tank Pipe

If the back leakage pipe (return to the tank) is obstructed, a pressure build-up will occur on the cam follower seal. This will result in over-fuelling and in extreme conditions the seal will be unseated.

5. Engine Depression Check

Connect vacuum gauge into depression signal line, i.e. in the pipe line between (centre pair) air intake manifold and the metering distributor vacuum connection. With engine running at 'tick over' speed (850 rev/min) gauge should read:

7" Hg (180 mm Hg) for TR5/6, and
12" Hg (305 mm Hg) for 2.5 litre.

If reading is low, reset tappets, synchronise throttle butterflies, and check ignition timing.

6. Fuel Supply

Finally, check that there is sufficient clean fuel in the petrol tank to supply the engine's requirements. (The fuel pump should deliver at least 100 cc (100 ml) in 5 seconds.)

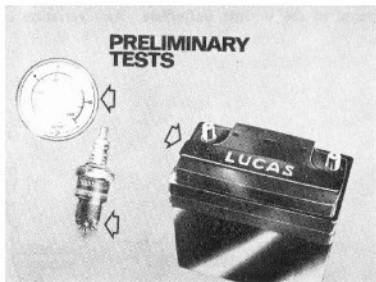

Fig. 12

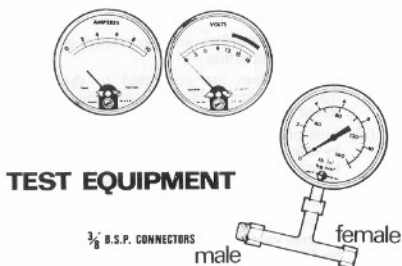

Fig. 13

TEST EQUIPMENT

The following items of test equipment are required for checking the petrol injection system:

- (i) Pressure gauge (see Figure 13) scaled for reading up to at least 160 lb/in² (1103.20 kN/m²).
- (ii) A 'T' piece, two $\frac{3}{8}$ " B.S.P. connections (one male and one female) and a suitable connection for the pressure gauge.
- (iii) A vacuum gauge 0-26" Hg (0-711 mm Hg).
- (vi) Ammeter (scale 0-10A).
- (v) Voltmeter (scale 0-18V).

Important

The fuel pump should never be switched on while any part of the fuel system, normally pressurised, is dismantled. Further, the fuel pump should not be run for long periods, when the engine is stationary.

The following precautions should also be taken before carrying out systematic fault diagnosis:

- (i) Whenever the pipes are removed from the petrol injection system, and the ignition is switched on, the feed cables must be disconnected from the pump.
- (ii) Cover exposed pipe with blanking plugs.
- (iii) Any sealing ring, removed during testing *must not* be re-fitted, but must be renewed.

When checking the 'PI' system the test equipment should be connected as follows:

- (a) **Vacuum gauge:** 'T' piece between (centre pair) air intake manifold and the metering distributor vacuum connection.
- (b) **Pressure gauge:** 'T' piece connected into petrol inlet at metering unit.
- (c) **Voltmeter:** Connected across pump motor terminals.
- (d) **Ammeter:** Connected in series with either of the pump motor leads.

With engine running at 'tick over' speed (850 rev/min) gauges and meters should read as follows:

Pressure gauge: 100-110 lb/in² (689.50-758.50 kN/m²) all models.

Vacuum gauge: TR5/6 7" Hg (180 mm Hg) 2.5 litre 12" Hg (305 mm Hg).

Volt drop should not exceed 1.5 volts.

Ammeter: should read not more than 5.5 amps.

DIAGNOSING FAULTS IN THE PETROL INJECTION SYSTEM

The following is a list of the more common faults encountered on PI equipped cars:

- | | |
|--|-------------------------------|
| 1. Misfiring | 5. Lack of response |
| (a) After cold start | 6. Engine cutting out |
| (b) After hot soak | 7. Vapour locking |
| 2. Rough idling | 8. Excessive fuel consumption |
| 3. Over-fuelling on one or more cylinders | 9. Engine fails to start. |
| 4. Under-fuelling on one or more cylinders | |

Important

Check Excess Fuel Lever

Before carrying out the systematic test procedure, the operation of the over-fuel lever should be checked over the complete test range as it may be the cause of symptoms 1 and 9 above. Ensure the lever moves into

(Continued)

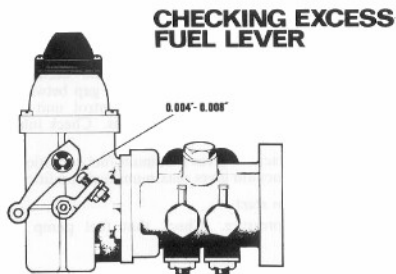

Fig. 14

the fully open position, and returns to the fully closed position, when the panel control is operated.

The clearance between the screw and the lever (when the lever is in the closed position) should be 0.004"–0.008" (0.10–0.20 mm), (Figure 14).

Faults, Possible Causes and Action

1. Misfiring

(a) After cold start

(i) One or more sparking plugs may be fouled by too rich a mixture due to excessive use of over-fuel lever. Remove plugs, clean and dry or replace as necessary. When starting, return over-fuel lever to normal running position as soon as possible.

(ii) Check that overfuel lever is responsive to manual control over its full range, and that when in the "off" position there is a clearance of 0.004"–0.008" (0.10 mm–0.20 mm) between the lever and the adjustment screw.

(iii) Throttle butterflies incorrectly set.

(iv) Check for air leaks at injector insulating blocks.

(v) Injector stuck open, remove and blow through with air line.

(b) After hot soak

(i) Check engine compressions.

(ii) If cylinder compressions are correct, locate cylinders which are misfiring and "crack" open union on injectors concerned to allow a small quantity of fuel to escape. Retighten unions and increase engine rev/min. If misfiring has now ceased, fault was due to partially empty injector lines and could have been caused by leakage of fuel or faulty non-return valves in outlet connections concerned. If the latter, renew faulty outlet connections; remembering to renew every seal which has been disturbed.

2. Rough Idling

(i) Throttle butterflies incorrectly set. Synchronise butterflies.

(ii) Injector pipes connected to the wrong injectors giving an incorrect injection sequence.

(iii) Check for air leaks which could lead to uneven air distribution.

3. Overfuelling on one or more cylinders

(i) Damaged grommet seals between nose of outlet connection and sleeve, allowing unmetered fuel to enter the injector line or lines giving continuous injection. On "Banjo" type outlets this can also occur if the inner 'O' ring on the "Banjo" is damaged.

(ii) Renew the seal on any line which is over-fuelling. (Remember: Renew any seal which has been removed, it must not be re-used.)

4. Under-fuelling on one or more cylinders

(i) Leaking connections on injector pipes or damaged pipes. Leaking "Dowty" washers. Tighten connections or replace pipes or washers.

5. Lack of response

(i) Throttle butterflies are incorrectly set. Synchronise butterflies.

(ii) Injector pipes are connected to the wrong injectors, giving an incorrect injection sequence. Rectify, as necessary.

(iii) Line pressure is low. Check line fuel pressure by inserting a pressure gauge in main petrol line, switching on the ignition. Gauge should read 100–110 lbf/in² (689.50–758.50 kN/m²). Adjust relief valve, if necessary.

(iv) Obstruction in the return to tank drain pipe. In extreme cases the cam follower diaphragm will be displaced.

(v) Metering unit timed to engine, is 180° out.

6. Engine cutting out on bends or on straight

(i) Installation is not modified as per Standard Triumph instructions. Correct as necessary.

(ii) Dirt in petrol tank momentarily obstructing the outlet pipe.

(iii) Transient failure in supply of electrical power to pump motor. Check all supply lines and connections in motor circuit.

7. Vapour locking

(i) Overheating of pump and motor, which in turn vaporizes fuel in pump element. Check fuel line pressure. If line pressure is high, this will overload motor and cause overheating. Check current consumption of motor does not exceed 5.5 amps at 13.5 volts. If current is above this figure, but line pressure is correct, remove motor for electrical and mechanical examination.

8. Excessive fuel consumption

(i) Check for (obvious) leaks at all petrol connections. Check operation of overfuel lever and clearance when in "off" position. Check for obstruction in return to tank drain pipe. Line pressure may be high. Check pipe and relief valve setting.

If a variable vacuum supply and accurate vacuum gauge is available, check gap between cam follower and rollers in control unit as detailed in workshop instructions. Check inlet manifold depression.

Note: High vacuum gives minimum fuel condition. Low vacuum gives maximum fuel condition.

9. Engine fails to start

Check line pressure. Check that fuel pump is operating.

TEST 1

Fuel Pump Not Operating – Electrical Check (in-situ)

If the engine fails to start, or is difficult to start, check that the fuel pump is operating satisfactorily. When the ignition is switched “on”, the fuel pump should start operating. (This is confirmed by hearing the note of the driving motor, or by feeling the slight vibrations in the body of the pump).

If the pump is not operating, connect a voltmeter across these cables, on the supply side, and an ammeter in one of the leads. When the ignition is switched on, the voltmeter reading should be 12 volts and the ammeter should read approximately 5 amperes, see Figure 15.

If the voltmeter reading is zero, one of the leads to the motor is open-circuit.

Low readings (for both voltage and current) indicate a high resistance in the circuit. The wiring to the motor should, therefore, be checked.

Any other variations in voltage and current readings indicate a faulty pump motor; possibly a defective brush assembly or open-circuit armature winding. Remove unit for further examination.

A high reading indicates a tight pump or stalled motor or short-circuited armature windings. Remove for further examination.

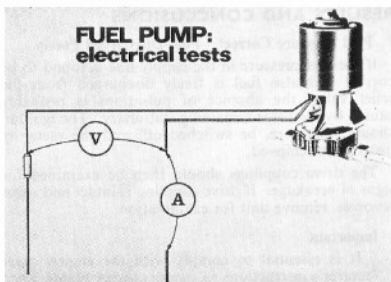

Fig. 15

TEST 2

Fuel Pump Operating – Feed-line Check (in-situ)

If the engine fails to start, or is difficult to start, but the fuel pump operates when the ignition is switched on, the ignition system should be disconnected. This is effected by disconnecting one of the LT cables at the ignition coil. The ignition switch is left in the “on” position. The engine is cranked by operating the starting motor. Each feed-line is gripped lightly in turn, and the pulsations are noted, see Figure 16.

Important

If the feed-lines are cleated together, they should be separated to avoid the misleading effects of “reflected pulsations”.

This test will show either:

- (i) that there are strong pulsations in all feed-lines.
- or (ii) that there are no pulsations in any feed-line.

(i) Strong Pulsations in All Feed Lines

These indicate that the petrol injection system is operating satisfactorily, and is unlikely to be the cause of engine failure.

(ii) No Pulsations in Any Feed-Line

If there are no pulsations in any feed-line, the fuel pressure should be checked. Insert a pressure gauge in the supply line (see Figure 17). Switch ignition on and note reading on pressure gauge, which should be within the limits 100–110 lbf/in² (689.50–758.50 kN/m²). To adjust, if necessary, switch off ignition and with a screwdriver inserted in the slot of the relief valve turn to adjust the fuel pressure. Switch on ignition and again note pressure reading. Repeat this operation until fuel pressure is within required limits.

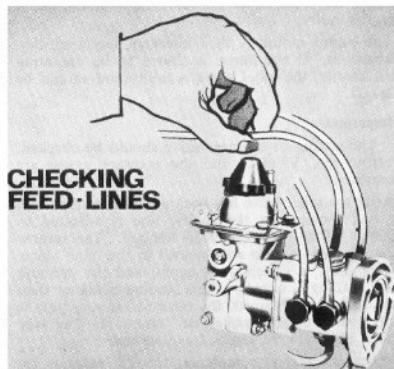

Fig. 16

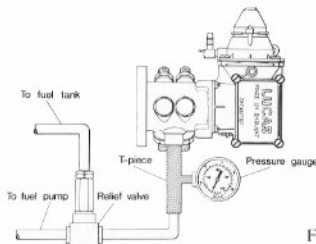

Fig. 17

RESULTS AND CONCLUSIONS

1. Fuel Pressure Correct Fuel Discharged Freely

If the fuel pressure in the supply line is found to be correct and also fuel is freely discharged from the relief valve, the absence of pulsations is probably caused by the rotor remaining stationary. The ignition should, therefore, be switched off, and the metering distributor removed.

The drive couplings should then be examined for signs of breakage. If drive coupling is intact and rotor revolves, remove unit for examination.

Important

It is essential to comply with the engine manufacturer's instructions to ensure correct timing when the metering distributor is re-fitted to the engine. See refitting instructions.

2. Fuel Pressure Zero - No Fuel Discharged

If no fuel is discharged from the relief valve, and the pressure gauge reading is zero, the fuel pump should be removed from the vehicle to enable the pump element and drive coupling to be examined.

3. Fuel Pressure Cannot be Adjusted

If the relief valve cannot be adjusted to give correct pressure readings, either the relief valve or the pump motor is faulty.

The pump motor is then checked, see workshop instructions. If the pump is shown to be operating satisfactorily, the relief valve is faulty and should be renewed.

Important

The setting of the new valve should be checked, before the 'T' piece and the pressure gauge are removed.

After the relief valve has been adjusted or replaced, the fuel pressure in the supply line is adjusted to 100-110 lbf/in² (689.50-758.50 kN/m²). The return-to-supply pipe is then reconnected to the relief valve. The ignition is switched on again, and the pressure gauge reading is noted. If this reading is higher than was previously obtained, the return-to-supply pipe is faulty (being either blocked or "kinked"). The pipe should, therefore, be serviced or renewed.

When the test is completed, the LT cable is re-connected to the ignition coil.

REMOVING METERING UNIT FROM ENGINE

Before removing the metering unit from the engine set static ignition timing.

- (i) Remove ignition distributor cap and check that rotor arm is pointing towards No. 1 electrode (cylinder) and contacts have just opened.
- (ii) Disconnect battery earth lead.
- (iii) Disconnect injector pipes at injectors.
- (iv) Disconnect vacuum pipe at metering unit.
- (v) Disconnect and blank off the fuel inlet pipe, and drain pipe.
Note: It is advisable to use hose clamps to prevent loss of fuel.
- (vi) Disconnect the cold start cable (to excess fuel lever) at the metering unit.
- (vii) Unscrew the two nuts securing drive housing to engine block pedestal.
- (viii) Remove pedestal from engine block complete with ignition distributor, metering unit and injector pipes.
- (ix) Remove three securing studs and separate metering unit from pedestal and drive housing. Remove drive coupling.

REFITTING METERING UNIT TO ENGINE

When refitting the metering unit, ensure that it is correctly timed to the engine. The rotor arm electrode should point towards No. 1 electrode in the ignition distributor cap, with the contact-breaker points just open.

- (i) Renew 'O' ring on engine block pedestal.
- (ii) Align scribe marks on rotor and metering unit fixing flange face.
- (iii) Place drive coupling in position.
- (iv) Refit metering unit to engine block pedestal. (Before refitting to engine, re-connect cold start cable to metering unit). Re-assemble to engine in reverse order to removal instructions.
- (v) Bleed injectors.

HOW TO CHECK METERING UNIT TO ENGINE TIMING

Turn engine until correct timing mark on crankshaft pulley is aligned to pointer with No. 1 cylinder on compression. Remove No. 6 outlet union from metering unit body and check that rotor port is showing partially open.

WORKSHOP INSTRUCTIONS

FOR

PETROL INJECTION EQUIPMENT—MARK II

AS FITTED TO

STANDARD-TRIUMPH TR5—TR6—2.5 LITRE 'PI'

VERY IMPORTANT NOTE

All 'P.I.' equipment, especially metering units not in use, should be flushed out and re-inhibited (see para 13 (b) for details) every 12 months. This is necessary to prevent possible rusting, and to avoid seizure of the close-fitting parts.

METERING DISTRIBUTOR/CONTROL UNIT

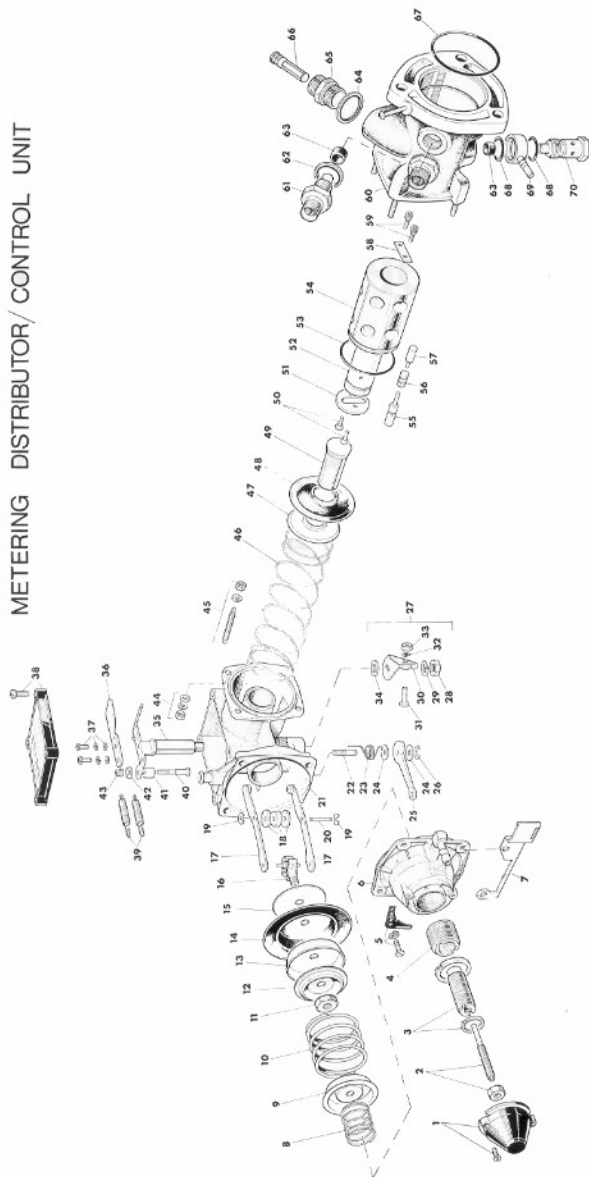

Fig. 18

KEY TO (FIGURE 18) EXPLODED ILLUSTRATION OF METERING/CONTROL UNIT

1. Depression chamber cover and fixing screws (2 off).
2. Centre (minimum fuel) screw and locking nut.
3. Intermediate calibration screw and locking ring.
4. Outer calibration screw and locking ring.
5. Depression chamber fixing screws and washers (4 off) and unit part number plate.
6. Depression chamber body.
7. Overfuel lever bracket stop.
8. Outer calibration spring.
9. Calibration spring carrier.
10. Inner calibration spring.
11. $\frac{1}{2}$ UNF nut.
12. Thrust plate.
13. Diaphragm support.
14. Diaphragm.
15. Diaphragm support plate.
16. Spherical bearing and datum link arms pivot.
17. Datum link arms.
18. Datum rollers - 2 outer 1 inner.
19. Datum link arm circlips.
20. Roller and link arm circlips.
21. Body assembly.
22. Overfuel lever pivot.
23. Overfuel lever return spring.
24. Washer.
25. Overfuel lever.
26. Circlip.
27. Overfuel lever assembly (with adjustment cam follower) screw.
28. $\frac{1}{2}$ UNF nut.
29. Spring washer.
30. Overfuel lever.
31. Cam follower adjustment screw.
32. Spring washer.
33. No. 6 UNC nut.
34. Spacer.
35. Datum track pivot arm assembly.
36. Datum track.
37. Fixing screws, No. 6 UNC nut and plain washer.
38. Datum track assembly cover and fixing screws No. 10 UNF (9 off).
39. Datum track spring(s).
40. Spring(s) anchor pin.
41. Spring spacer.
42. Spacer.
43. Locktite nut.
44. Nut, spring washer and plain washer (4 off each) distributor body fixing.
45. Maximum fuel screw spring washer and No. 10 UNF nut.
46. Cam follower spring.
47. Thrust plate.
48. Diaphragm seal.
49. Cam follower.
50. Rotor thrust plate (socket-headed countersunk) fixing screws.
51. Rotor thrust plate.
52. Rotor.
53. Sleeve 'O' ring.
54. Sleeve.
55. Control stop.
56. Shuttle.
57. Fixed stop.
58. Rotor retaining plate.
59. Fixing screws (socket-headed).
60. Body assembly.
61. Outlet union.
62. Sealing washer.
63. Seal.
64. Sealing washer.
65. Inlet union.
66. Filter.
67. Metering distributor body 'O' ring.
68. Banjo 'O' ring seal.
69. Banjo connector.
70. Banjo bolt.

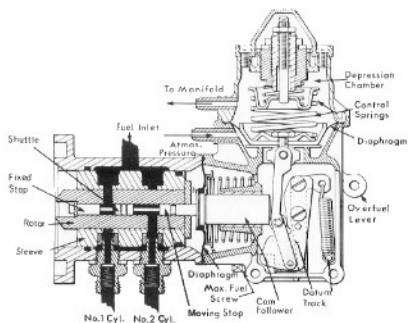

Fig. 19

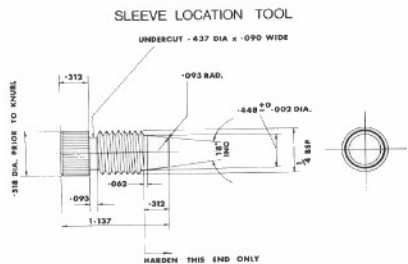

Fig. 20

SEALING RING LOCATION TOOL

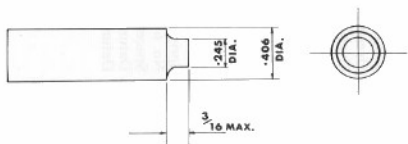

Fig. 21

DISMANTLING AND RE-ASSEMBLY OF METERING DISTRIBUTOR/CONTROL UNIT

- The metering distributor/control unit can be dismantled without difficulty and special calibration equipment is not required, providing the following parts are not disturbed:
 - The three calibration screws on the end of the depression chamber.
 - The full load setting screw.
 (These are shown in Figure 18 items 2, 3, 4 and 45).

Important

UNLESS THE NECESSARY CALIBRATION EQUIPMENT (CONSISTING OF A VARIABLE VACUUM SUPPLY 0-28" Hg AND GAUGE AND SUITABLE TEST RIG) IS AVAILABLE, THE CALIBRATION SCREWS MENTIONED ABOVE MUST NOT BE DISTURBED.

IF A NEW CONTROL UNIT IS FITTED TO A DISTRIBUTOR OR VICE-VERSA, OR ANY NEW PARTS FITTED OTHER THAN SEALS RE-CALIBRATION WILL BE NECESSARY.

CLEANLINESS OF WORK AND TOOLS

As cleanliness of petrol injection equipment is of vital importance, the working area of the bench, and the tools should be thoroughly clean at all times. In addition, all the internal parts of the equipment should be washed in clean kerosene before re-assembly. The rotor and sleeve assembly is particularly vulnerable to dirt and damage through mishandling. When removed from the metering unit, it must be placed where it cannot be knocked or scratched.

2. DISMANTLING METERING DISTRIBUTOR/CONTROL UNIT

Before dismantling the unit, examine it for damage, external evidence of fuel leaks and general condition. The unit must be renewed if there is evidence of external fuel leakage due to damage. The two tools, shown in Figs. 20 and 21, are required. Both can be made without difficulty in a local workshop, and are essential when re-building the unit.

(a) Separating the Metering Distributor from Control Unit

- Remove the four nuts which secure the mixture control unit to the metering distributor.

Note: The balance spring of the cam follower is compressed between these two units, so they must be held together while the nuts are undone and then allowed to part slowly. The spring and cam follower are then removed.

(b) Dismantling the Control Unit

- Remove coverplate securing screws and take off coverplate.

- (ii) Remove securing screws from depression chamber cover, and take off cover.
- (iii) Take off the depression chamber after removing the four fixing screws and the overfuel lever cable bracket. The calibration springs, spring carrier, diaphragm and link arms can now be removed. If the diaphragm assembly and links are to be dismantled, proceed as follows:— Hold spherical bearing and remove diaphragm securing nut. The thrust plate, diaphragm support, diaphragm and backing plate can now be separated in that order.
- (iv) Unhook the pivot shaft/datum track return spring.
- (v) Unscrew and remove nut and lock washer from overfuel lever cam follower pivot shaft and take off cam follower assembly; withdraw datum track assembly together with pivot shaft.
- (vi) Remove return spring, circlip and washer from overfuel lever and lift off lever and spring.
- (vii) Place diaphragm/seal and cam follower from the metering distributor on the bench with diaphragm uppermost. Position the thumbs on either side of the thickened inner edge of the diaphragm. Gently press downwards, and slide the diaphragm off the cam follower.
- (viii) If the calibration adjustment screws are to be removed, temporarily bolt the metering distributor and control unit together. This enables extra leverage to be applied to the calibration screws. Do not clamp either unit in a vice.

(c) Dismantling the Metering Distributor

- (i) Remove banjo unions.
- (ii) Remove inlet union and strainer, and all outlet unions, before dismantling the metering distributor further.
- (iii) Remove 'O' rings. A stout wire hook will aid removal. (New 'O' rings must be fitted when re-assembling.)
- (iv) Apply gentle pressure at the drive end of the sleeve, and push the sleeve out of the body.
- (v) Remove distributor body 'O' ring, and discard.
- (vi) Remove sleeve 'O' ring, and discard.
- (vii) Remove the two socket-headed screws (from rotor retaining plate) holding the small plate at drive end of rotor. Remove the control stop, shuttle, and fixed stop, by pushing them out with a nylon knitting needle or other non-metallic instrument.
- (viii) Withdraw rotor from sleeve and place on a clean surface where it will not be damaged.

3. RE-ASSEMBLING METERING DISTRIBUTOR/CONTROL UNIT

(a) Metering Distributor

- (i) Ensure that both countersunk screws in rotor thrust plate are tight.

- (ii) Check that non-return valves in all outlet unions are seating correctly. Place the tapered end of union in kerosene, and blow through the other end to see if the valve is leaking. (*Do not use an air line as the valve seat may be damaged by the high pressure.*) If the valve proves to be leaking, however slightly, a new union must be used.
- (iii) Fit strainer to fuel inlet union, at the end with longest thread.
- (iv) Fit new seal to fuel inlet union, and fit union to body.
- (v) Wash body in clean kerosene.
- (vi) Fit new body 'O' ring.
- (vii) Wash rotor and sleeve in clean kerosene and assemble while still wet. Take care when inserting rotor into the sleeve, not to get it jammed. Ensure that the brass thrust plate is at the 'O' ring end of sleeve, and that the rotor and sleeve turn freely after assembly.
- (viii) Place rotor stop in position.
- (ix) Fit rotor stop (socket-headed) securing screws and tighten to 16 lbf.
- (x) Check that rotor rotates freely and that there is a little end-float.
- (xi) Fit a *new* 'O' ring to the sleeve.
- (xii) Smear a little clean engine oil on both body and sleeve 'O' rings.
- (xiii) Locate sleeve in body and push home until sleeve ports are approximately in line with the threaded holes in body.
- (xiv) Screw sleeve location tool into one of the outlet ports in the body so that it engages with the sleeve port.
- (xv) Using the 'O' ring tool fit a *new* ring to each outlet port, and ensure it is firmly located. Remember to fit an 'O' ring to the port containing the sleeve alignment tool.
- (xvi) Fit outlet unions and washer to each body port.
- (xvii) Fit *new* 'O' rings to banjos and fit banjo unions.
- (xviii) Wash the fixed stop, shuttle and control stop in clean kerosene and, while still wet, assemble in that order into the rotor. (The control stop can be identified by the hole in the groove.)
- (xix) Fit plastic blanking plugs to all unions.
- (xx) Place the metering distributor to one side, in an upright position, so that the shuttle and control stops cannot fall out of the rotor.

(b) Control Unit

- (i) Fit overfuel lever pivot shaft and lever assembly. First the pivot shaft, and then the thick spacer; followed by the overfuel lever, spring washer and nut.
- (ii) Fit the overfuel lever return spring so that spring leg protrudes into the housing.
- (iii) Place a flat washer over the spring.
- (iv) Fit overfuel lever with extended portion facing the drive end of the metering distributor.

(Continued)

- (v) Fit a flat washer and secure the assembly with a circlip.
- (vi) Fit the pivot shaft/datum track spring.
- (vii) Assemble the rollers to the control links – small roller in the middle, large rollers with chamfered edge facing inwards. This should be done by first fitting the roller pivot to one of the links and securing with a circlip. The rollers can be located in position by rotating the link so that the pivot pin is uppermost.
- (viii) Next, place the spherical bearing in position at the end of the link.
- (ix) Fit the remaining link arm and secure with circlip.
- (x) Replace the backing plate, diaphragm, diaphragm support and spring seat in that order.
- (xi) Screw on the diaphragm locking nut and tighten to 4 lbf (17.80 N).
- (xii) Lightly smear link rollers with a little Rocol MD-0.
- (xiii) Re-fit link arm and diaphragm making sure that spherical seat and link arm are square with the rest of the assembly.
- (xiv) Push diaphragm rim into its seating on the body.
- (xv) Assemble calibration springs – large spring on the diaphragm, then spring carrier and small spring.
- (xvi) Fit depression chamber cover and overfuel lever bracket. The bracket should be positioned so that its cranked end is nearest the drive end of the metering distributor. The air inlet connection must be positioned on the opposite side to the banjo connections. Note that the two longest fixing screws are used on the bracket side of the cover.
- (xvii) Position the cam follower diaphragm with the three locating slots uppermost, feed cam follower through hole in diaphragm. (The diaphragm can be pushed on to its seating on the cam follower by finger pressure).

4. RE-ASSEMBLY OF METERING DISTRIBUTOR TO CONTROL UNIT

- (i) Fit spring thrust plate over cam follower.
- (ii) Position cam follower and spring between the control unit and metering distributor and secure one to the other. Ensure that the diaphragm seal is seated correctly.

5. SETTING THE DATUM TRACK ANGLE

After re-assembling the metering unit, some mechanical settings or adjustments must be made before the unit is tested on the test bench.

Note: These initial adjustments ensure that the angle of the datum track is correct. Otherwise, there will be reduced performance at engine idling speed and at light load conditions. When setting the metering unit, adjust the maximum fuel screw and the datum track to obtain the required gap between rollers and cam follower.

The complete calibration procedure is necessary if the calibrating screws have been moved from their original setting.

(a) Test Equipment Required

- (i) A fully equipped fuel injection test bench.
- (ii) A set of flat feeler gauges.
- (iii) A tool to assist in the setting operation. (A 16AC end bracket fixing bolt can be used, provided it is threaded along its entire length. Alternatively, a $\frac{5}{16}$ " UNF bolt, at least $3\frac{1}{2}$ " (89 mm) long, with two locknuts can be used, see Fig. 23.
- (iv) A collar 0.540" (13.72 mm) thick to fit over the bolt. See Fig. 23.
- (v) A datum track locking tool (see Fig. 22a).

(b) Setting Procedure

The procedure concerns adjusting the control unit datum track to the correct angle, and also the amount of roller travel. With the metering unit bolted to the test bench the sequence is as follows:

- (i) Remove plastic covers from the depression chamber and datum track housing.
Note: Replace the depression chamber cover fixing screws.
- (ii) Remove minimum fuel stop screw and locknut, see Fig. 23.
- (iii) Insert locking tool and check that clearance between the roller and the cam follower (see Fig. 22, position 1), is 0.058" (1.47 mm).
- (iv) If incorrect, remove locking tool and adjust datum track by means of the maximum fuel screw until 0.058" (1.47 mm) clearance is obtained. Repeat (iii) with locking tool in position.
- (v) Insert $\frac{5}{16}$ " UNF bolt complete with locknuts in place of minimum fuel stop screw. Screw bolt until it just bottoms on the spherical bearing stop pin, see Fig. 23.
- (vi) Screw locknuts against inner spring stop and lock together on the bolt.
- (vii) Unscrew bolt with both nuts locked together, until 0.540" (13.72 mm) collar just fits between locked nuts and inner spring stop, see Fig. 23.
- (viii) Apply vacuum to depression chamber. (17" Hg for TR5 unit and 24" Hg for TR6 and 2.5 'P.I.' units).
- (ix) Place a flat feeler gauge between roller and cam follower. 0.012" (0.30 mm) for TR5 unit and 0.002" (0.050 mm) for TR6 and 2.5 'P.I.' units.) See Fig. 22, position 2.

(Continued)

(x) Loosen the two datum track securing screws and adjust datum track until required clearance is obtained. Re-tighten securing screws and check clearance.

(xi) Return depression chamber to atmospheric pressure and re-check 0.058" clearance at position 1 (see Fig. 22) re-adjusting if necessary. Re-fit the minimum fuel stop screw and locknut.

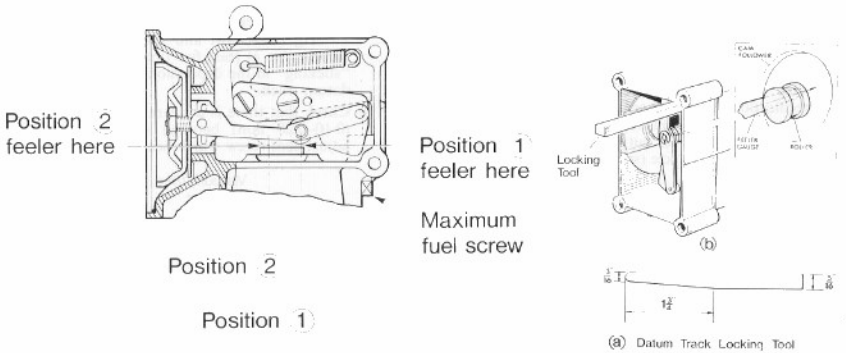

CONTROL TRACK PRESETTING

Fig. 22

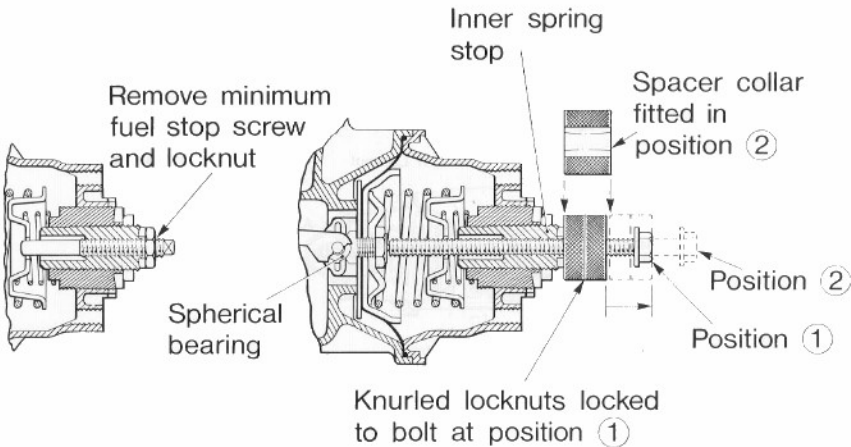

FITTING SPACER COLLAR AND BOLT

Fig. 23

6. BENCH TESTING THE METERING DISTRIBUTOR/CONTROL UNIT

Having made the initial adjustments, the metering unit is tested to check the fuel output over the full operating range (including maximum and minimum requirements).

The output requirements of the metering unit vary with the vehicle to which it is fitted, so ensure that it is checked against the correct figures.

Important

If the output performance does not conform to specification, the metering unit requires recalibrating. The adjustment of the calibration screws affects the fuel output and hence the performance of the vehicle (see Figures 24 and 25).

(a) Testing Procedure

- (i) Bolt the metering distributor to the drive flange of the test bench. Ensure that the unit is mounted in the same position as on the vehicle. (Control datum track should be vertical). Remove rectangular cover plate.
- (ii) Connect outlet unions to injector pipes.
- (iii) Connect measuring glass to leak off drain. Connect fuel supply to inlet connections.

Note: Test fuel should be Fawley White Spirit No. 100; plus 50 parts per million Santoline 'C' inhibitor, or Shell Calibrating Fuel 'C'.

- (iv) Switch on test bench and gradually increase speed to 1000 rev/min. Operate overfuel lever several times over full movement. Check that there is approximately the same amount of fuel

in each sight glass. Fuel should be dripping from the leakage drain.

This check proves that there are no obvious faults such as leaking or blocked pipes etc. It also ensures that all air is removed from the pipes.

- (v) Connect a variable vacuum supply 0-28" Hg (711.2 mm) to the control unit depression chamber. Increase vacuum to approximately 25" Hg (635 mm) and then reduce to zero. Repeat this at least five times to eliminate any "sticking" in the depression chamber or on the datum track.
- (vi) Check that there is a clearance of 0.004-0.008" (0.10-0.20 mm) between overfuel lever and adjustment screw which bears on the cam.

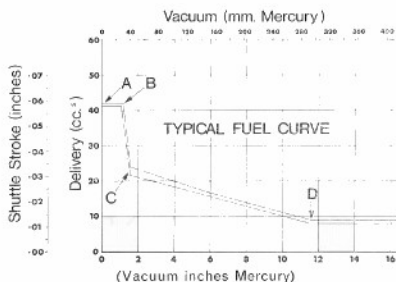

Fig. 24

CALIBRATION ADJUSTMENTS INCORPORATED IN LUCAS MK 2 PI CONTROL

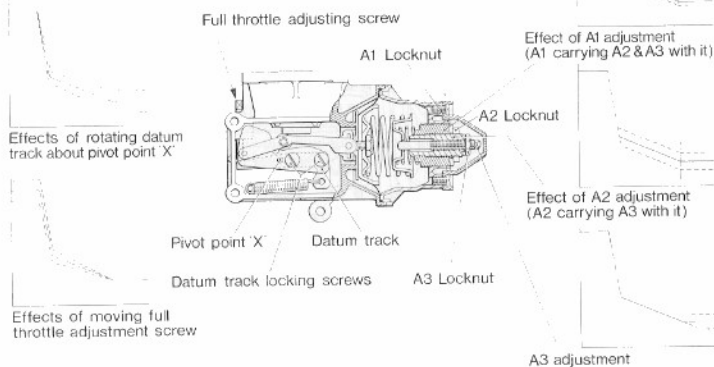

Fig. 25

- (vii) Maintain speed of test bench at 1000 rev/min, and fuel supply pressure at 100 lbf/in² (689.50 kN/m²). Check performance of metering distributor/control unit. Adjust vacuum to minimum figure in specification tables, and check the amount of fuel delivered to each sight glass. Then, adjust vacuum to next figure in the table, and again check amount of fuel delivered.

(b) Test Specifications

TR5

Vacuum Gauge Reading (in Hg)	Quantity of Fuel Collected (cc's) per 1000 Injections	
	Minimum	Maximum
0.0	41.5	42.5
0.9	41.5	42.5
1.1	38.0	40.0
1.4	28.0	30.0
3.0	19.9	21.5
9.0	11.7	12.3
17.0	8.0	9.0

Note: Minimum fuel screw (overrun stop) set at 17" Hg (min fuel).

TR6

Vacuum Gauge Reading (in Hg)	Quantity of Fuel Collected (cc's) per 1000 Injections	
	Minimum	Maximum
0.0	41.0	42.0
0.7	41.0	42.0
1.0	35.5	38.5
1.3	27.9	30.9
3.0	21.5	23.1
6.0	15.7	16.8
9.0	11.3	12.1
10.5	9.4	10.0
20.0	1.5	3.0

Note: Minimum fuel screw (overrun stop) set at 20" Hg (min fuel).

2.5

'P.I.'

Saloon

Vacuum Gauge Reading (in Hg)	Quantity of Fuel Collected (cc's) per 1000 Injections	
	Minimum	Maximum
0.0	41.0	42.0
0.7	41.0	42.0
1.0	35.0	38.0
1.4	25.0	28.0
3.0	21.5	22.8
6.0	17.1	18.3
9.0	13.6	14.7
12.0	10.0	11.0
24.0	1.5	3.0

Note: Minimum fuel screw (overrun stop) set at 24" Hg (min fuel).

7. ALTERNATIVE TESTING PROCEDURE

If a fuel injection test bench is not available, there is an alternative method of checking the output performance of the metering unit. This involves measuring between the cam follower face and the rollers on the datum track, at various vacuum

gauge readings, and checking the amount of roller travel.

The equipment required is:

- a variable vacuum supply, 0–26" Hg (711.2 mm);
- a set of flat feeler gauges;
- a pair of dividers, and
- a datum track locking tool.

(a) Testing Procedure

Bolt the metering unit to a metal plate. Clamp the plate in a vice so that the unit is in the same plane as when fitted to the vehicle, that is, with datum track vertical. The testing procedure is as follows:

- Check clearance between overfuel lever adjustment screw and cam on which it runs. Clearance should be within the limits of 0.004"–0.008" (0.10–0.20 mm) when lever is in the "at rest" position.
- Remove large (datum track) rectangular cover, and insert locking tool.
- Check that gap between cam follower face and rollers is 0.058" (1.47 mm) in "at rest" position. Reset if necessary, by adjusting the maximum fuel screw with locking tool removed. Re-insert locking tool and again check clearance.
- Connect variable vacuum supply to the depression chamber.
- Increase vacuum to approximately 25" Hg and then reduce to zero. Repeat this at least five times to eliminate any "sticking" in the depression chamber or on the datum track.
- Roller travel should be 0.540" (13.72 mm) check as follows:
 - Measure distance of edge of rollers from a datum point on control box with a pair of dividers.
- Increase opening of dividers by 0.540" (13.72 mm).
- Apply a depression of at least 25" Hg to depression chamber.
- Again measure distance from original datum point to edge of roller with reset dividers. Rollers should have moved 0.540" (13.72 mm).
- Check the gap between cam follower face and roller at different depressions as shown in the specification tables (b).

Note: The feeler gauge must be inserted in line with the centre of the rollers, and must be in contact with both roller edges. The feeler gauge should slide easily between the rollers and the cam follower.

(b) Test Specifications

TR5

Vacuum Gauge Reading (in Hg)	Gap between Cam Follower and Roller	
	Inches	Millimetres
0	0.058	1.47
3	0.025	0.63
6	0.019	0.48
9	0.014	0.35
17	0.012	0.30

(Continued)

Vacuum Gauge Reading (in Hg)	Gap between	
	Cam Follower and Roller Inches	Millimetres
0	0.057	1.44
3	0.031	0.78
6	0.023	0.58
10.5	0.013	0.33
20	0.002	0.05

2.5 'P.I.' Saloon

Vacuum Gauge Reading (in Hg)	Gap between	
	Cam Follower and Roller Inches	Millimetres
0	0.057	1.44
3	0.030	0.76
6	0.024	0.60
12	0.013	0.33
24	0.003	0.07

8. EFFECTS ON FUEL DELIVERY PERFORMANCE WHEN ADJUSTING CALIBRATION SCREWS

If the fuel delivery of a metering unit does not conform to specification, the calibration screws must be adjusted. Each calibration screw has a particular effect on fuel delivery, and it is advisable to study these so that the minimum of adjustments can be made when calibrating.

Setting the datum track angle (see section 5, page 22) is the first part of the calibration sequence and it may be necessary to re-adjust the setting when bench testing. It may also be necessary to adjust other calibration screws even though they were not disturbed during dismantling and re-assembly.

It will be seen from the fuel delivery specifications, that testing starts with maximum fuel delivery, and is then checked step by step down to minimum fuel requirements, against a rising vacuum.

The fuel delivery curves shown in Figures 24 and 25 are typical only. They illustrate how the setting of the various calibration screws affects fuel delivery.

(a) Outer Screw A1

This screw acts as a stop for both the large and small springs in the depression chamber, and determines the pre-load on them during maximum fuel conditions (wide open throttle). Varying its position will alter the position of point 'B' and curve line 'B' to 'C', see Figs. 24 and 25. If the screw is turned too far anti-clockwise the fuel delivery at full throttle will be reduced due to the small depression in the manifold, caused by the air cleaner, etc.

(b) Intermediate Screw A2

The position of this screw determines the travel of the spring thrust plate. When the thrust plate touches the end of this screw, the diaphragm deflection is controlled by the larger spring. This is position 'C' on the fuel curve. Screwing anti-clockwise will reduce fuel delivery between points 'C' and 'D', see Figures 24 and 25.

(c) Centre (Minimum Fuel Stop) Screw A3

This screw (Fig. 25) limits the travel of the linkage and rollers towards the minimum fuel position. Its main purpose is to prevent the cam follower forcing the control stop fully home and so reducing the fuel to zero. This stop only comes into operation under "high" vacuum conditions on overrun of the engine. Point 'D' on the fuel curve Fig. 24.

(d) Maximum Fuel (Full Throttle) Screw

The datum track is held by spring pressure against an adjustable stop. The position of this stop can be altered by slackening the locknut and screwing the stop in or out. Clockwise rotation will increase the full load (maximum fuel supply). It will also affect the curve, as shown in Fig. 25.

(e) Datum Track Adjustment Screws

Altering the angle of the datum track, by slackening the two fixing screws and moving the datum track on its carrier (about the centre pivot) will mainly affect the engine performance at idling speed and in light load conditions. See fuel output curve, Fig. 24.

9. CALIBRATION ADJUSTMENTS DURING FUEL DELIVERY TESTS

As stated earlier, the performance of the metering unit is checked against the specification figures for the particular vehicle. Several checks are made at specified points on a rising vacuum to ascertain whether the fuel delivery is within specified limits. If fuel delivery rate is outside the stated limits, re-calibration must be carried out before proceeding to the next stage. This is because the calibration screws (sleeves) are interlocked. When the position of a calibration screw is altered (by screwing in or out) the position of the others is also altered, and will require individual adjustment. The large outer screw and the maximum fuel screw should be adjusted to correct the line 'A' to 'B'. The intermediate screw controls the line crossover point 'C'. If the initial datum track angle procedure has been carried out correctly the line 'C' to 'D' should normally be correct. If not, re-adjustment starting at the datum track will be necessary.

Always start re-testing from the beginning after making any adjustment. Also, ensure that the sight glasses are empty before starting to re-test.

PUMP & MOTOR ASSEMBLY (Mk.2)

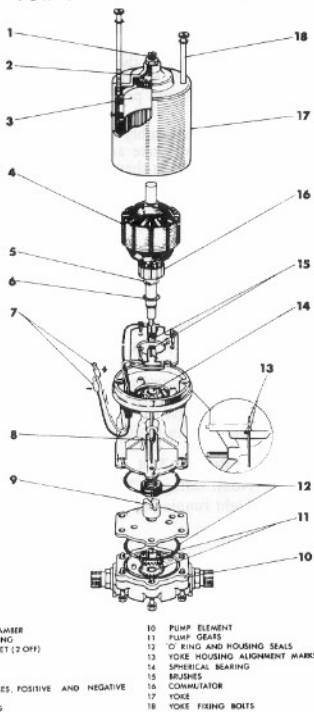

- | | |
|---|---------------------------------|
| 1 END FLOAT CHAMBER | 10 PUMP ELEMENT |
| 2 SPHERICAL BEARING | 11 PUMP GEARS |
| 3 CERAMIC MAGNET (2 OFF) | 12 'O' RING AND HOUSING SEALS |
| 4 ARMATURE | 13 YOKE HOUSING ALIGNMENT MARKS |
| 5 CIRCLIP | 14 SPHERICAL BEARING |
| 6 SHIM WASHER | 15 BRUSHES |
| 7 PRE-WIRED CABLES, POSITIVE AND NEGATIVE | 16 COMMUTATOR |
| 8 DRAW PIPE | 17 YOKE |
| 9 DRIVE COUPLING | 18 YOKE FIXING BOLTS |

Fig. 26

10. DISMANTLING AND SERVICING OF FUEL PUMP AND MOTOR

The fuel pump and "permanent magnet" motor (Fig. 26) can be dismantled and re-assembled without the use of special tools.

A 110 volt A.C. mains connection will be required for insulation tests on the pump motor armature; and a lathe for skimming the armature should this be necessary.

Note: It is essential that the working area on the bench is clean (free of dirt, metal and swarf etc.) otherwise it will be attracted inside the yoke by the exposed field magnets. A piece of clean rag pushed into the yoke will help to keep out any dirt etc.

When re-assembling the yoke to the armature do not allow it to snap hard against the ceramic magnets and damage them.

(a) Dismantling Procedure

- (i) Remove the six bolts which secure the pump unit to the pump housing and withdraw pump unit. (The pump unit components are not serviced individually. Fit a complete new unit if original is faulty).
- (ii) Remove and discard the 'O' ring situated in the end of the pump housing.
- (iii) Remove the two through bolts which secure the yoke to the housing. Grip the exposed tongue of the armature shaft with a pair of pliers and gently remove the armature and housing assembly from the yoke.
- (iv) Hold the housing in a vertical position (armature uppermost) and gently withdraw armature from housing.

Note: At this stage the assembly must be held in a vertical position to ensure that the shimming washer(s) on the armature shaft slide off as the armature is withdrawn. Otherwise, they will stick to the armature and damage the brushes as the armature is withdrawn.

(b) Serviceability of Parts

- (i) *Brushes*
Fit new brush plate assembly if brushes are worn to less than 0.125" (3.17 mm) in length.
- (ii) *Armature*
Use an armature tester to check armature for open or short-circuited windings. Check armature insulation using a 15W 110 volt A.C. mains test lamp connected between each commutator bar and armature shaft. Armature resistance between adjacent commutator bars should be within the limits 0.16 to 0.24 ohms at 15°C.
- (iii) *Commutator*
The commutator should be cleaned using a petrol moistened cloth, and light scratches removed by polishing with a very fine glass paper. A badly scratched or worn commutator should be skimmed on a high-speed lathe. Do not remove more metal than is necessary. **DO NOT UNDERCUT THE INSULATORS BETWEEN THE ARMATURE SEGMENTS.**

(Continued)

(iv) *Pump Unit*

Visually examine for signs of wear etc. The pump unit must be renewed, if worn, as component parts are not serviced individually.

(v) *Coupling*

Visually examine for signs of wear etc., and renew if necessary.

(c) **Pump Motor Rubber Seal**

Evidence of petrol discharge from the small drain pipe on the body casting indicates failure of the rubber seal (between the pump and motor) through which the drive shaft passes. In such cases fit a new seal. To check the seal proceed as follows:

- (i) Connect the pump inlet to a kerosene supply.
- (ii) Connect a pipe to the pump outlet union, and immerse the free end in kerosene.
- (iii) Connect the motor cables to a 12 volt D.C. supply.
- (iv) When the pump is running and held well above the kerosene supply a continuous flow of bubbles discharged from the outlet pipe indicates that the seal is faulty.

(d) **Re-assembly of Pump and Motor**

Re-assembly of the pump and motor is the reverse of the assembly procedure. Great care must be taken to avoid damaging the thicker petrol seal (see 12 in Figure 26) when passing the armature

shaft drive tongue through the base casting. The seal should be smeared with grease (Shell 6266) before assembling and a temporary protective cover fitted over the end of the armature shaft. (Figure 27 gives the dimensions for making a suitable cover. Alternatively, the bullet-shaped cap from a ball-point pen can be used as a protective cover).

Ensure the assembly marks (see 13 in Figure 26) on the motor yoke and body casting are in line when assembling them together, otherwise reverse rotation will result.

Bolt pump and motor together after checking that the drive assembly is satisfactory, and correctly located.

(e) **Armature End-Float Adjustment**

After assembling pump and motor, hold the pump unit with the yoke vertical (end-float adjustment screw uppermost) and proceed as follows:

- (i) Slacken the locknut for end-float adjustment screw and screw in adjuster until resistance is just felt. Screw the adjuster back a $\frac{1}{4}$ of a turn to give the correct end-float within the limits 0.004" to 0.010" (0.10 mm to 0.25 mm). Lock the screw in position.

(f) **Light Running Test**

Nom. voltage: 12 volt.

Light running current: at 13.5 volt and 2200 rev/min is 1.4 amperes.

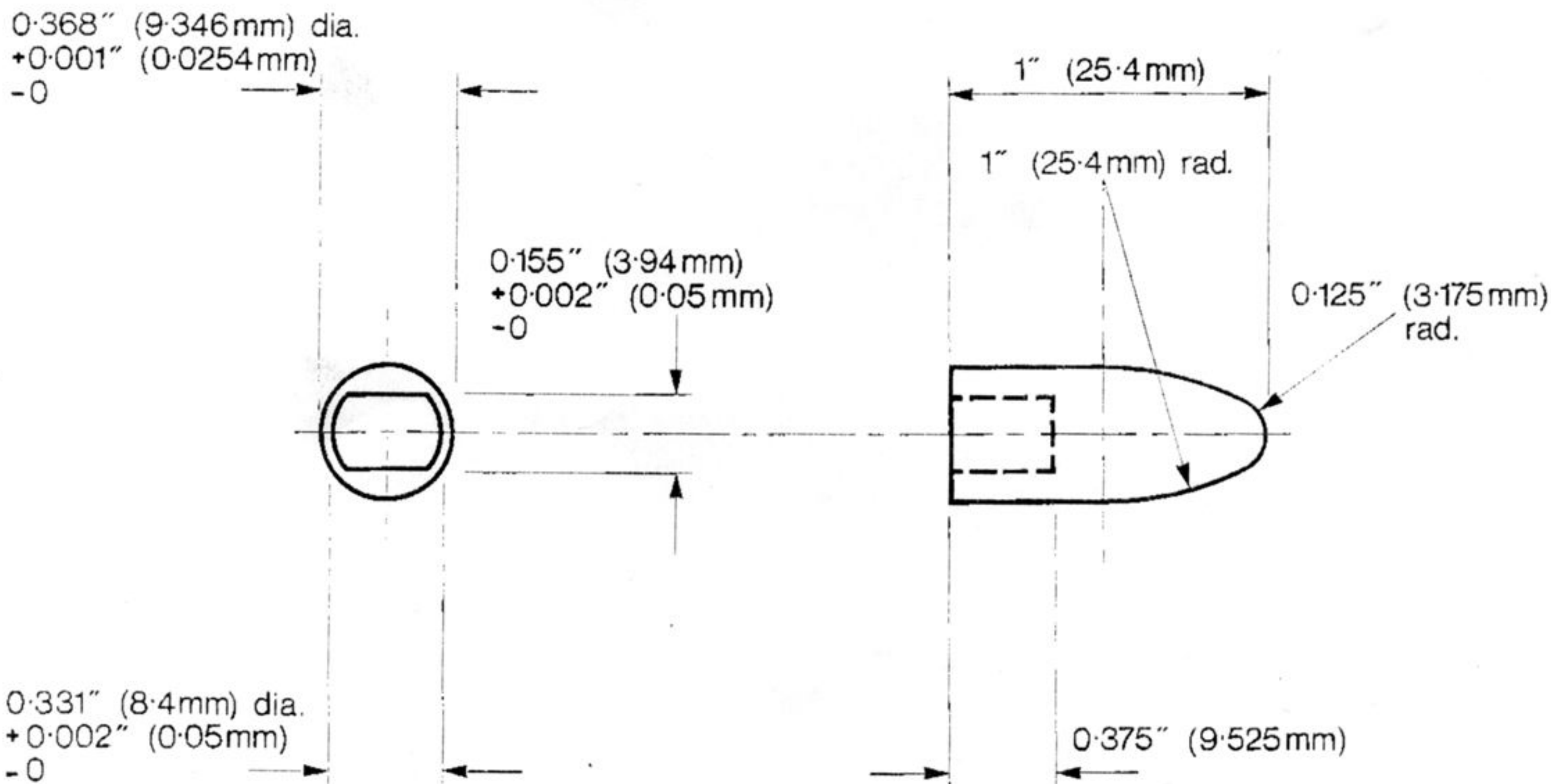

Fig. 27

11. FITTING UNIONS ON FUEL INJECTION PIPES

In order to fit unions to fuel pipes, a suitable pipe clamp must be provided.

Figure 28 illustrates a simple clamp made from Tufnol block (approximately 2" x 1" x 1"). A 1/4" diameter hole is drilled through the centre of the block, which is then cut along its centre line. Cut the piping to the required length and clamp it as shown in Figure 28. Allow approximately 1/8" clearance above the clamp, in addition to the length of pipe required. If a straight connection is being made, place the union nut over the pipe before it is clamped.

Locate the connector in the pipe and gently tap it into its final position, using a soft-headed hammer. Remove dust particles from the interior of pipe with compressed air.

Note: The pipe must not be heated and the union assembly should be fitted cold. Part Numbers for ordering piping and respective connectors are as follows:

Piping (50 ft)	54733455
Elbow connector	54730924
Banjo	54731886
Straight connector	54733399

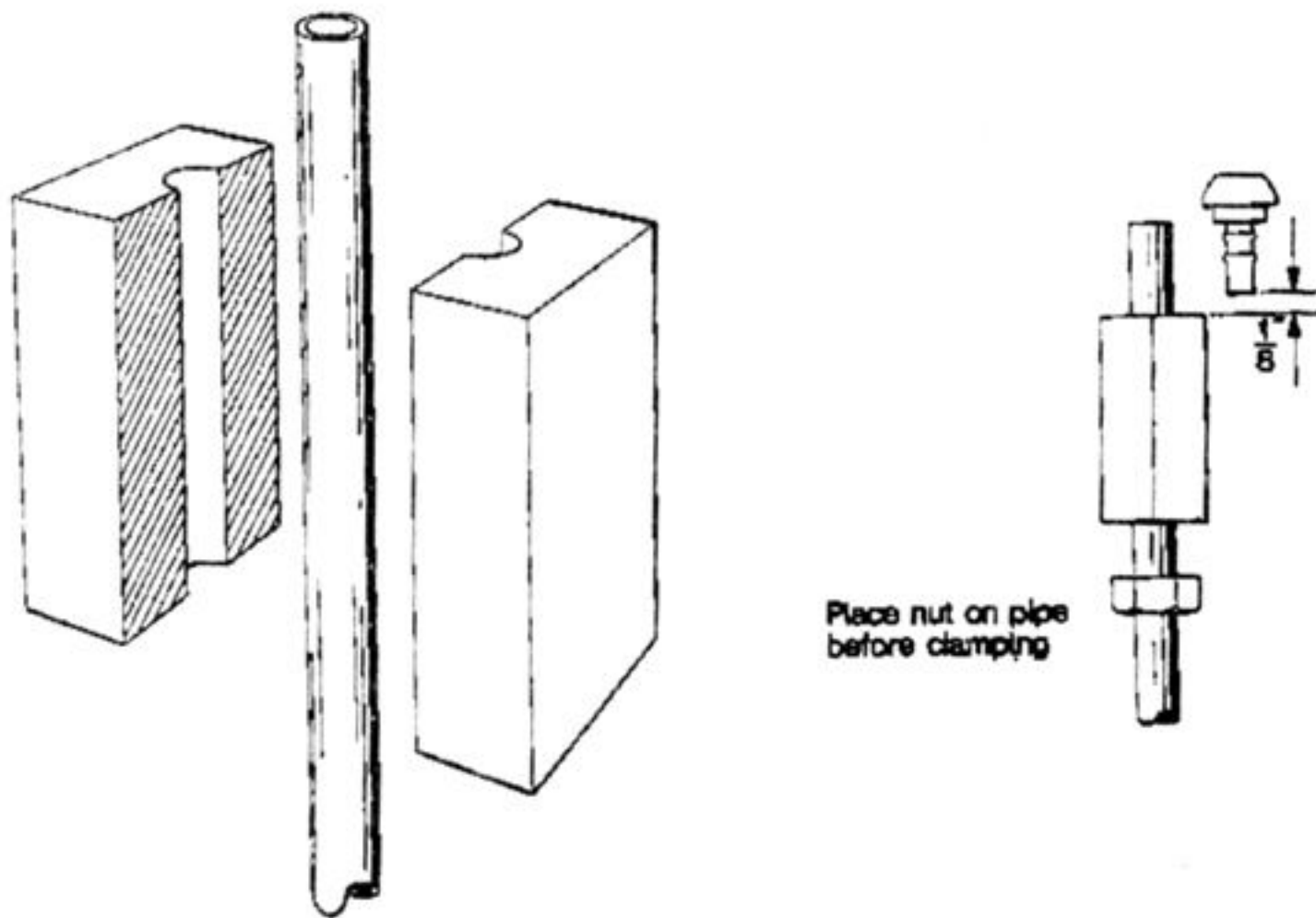

Fig. 28

12. BENCH TESTING RELIEF VALVE

This test should be made with the relief valve connected to a suitable test rig. Test fuel must be Fawley White Spirit 100 inhibited with 50 p.p.m. (parts per million) Santolene 'C'. (See Section 17, page 30).

The procedure is as follows:

- (i) Assemble relief valve to test rig and flush the valve several times with test fuel from 0-25 g.p.h. to ensure the valve is clean before proceeding with tests.
- (ii) Slowly increase pressure to 20-25 lbf/in² (137.89-172.36 kN/m²). Check that air bleed is functioning. (There must be a minimum flow of 1 gallon per hour (g.p.h.) with the bleed open). Check that bleed closes at pressures above 25 lbf/in² (172.36 kN/m²) indicated by bleed flow reduction.
- (iii) Slowly increase pressure to 100 lbf/in² (689.50 kN/m²). At this pressure maximum leakage flow rate should be 1 1/2 g.p.h.
- (iv) Increase pressure until a flow rate of 17 g.p.h. is obtained and note pressure. This must not exceed 108 lbf/in² (744.60 kN/m²).
- (v) Reduce pressure to 100 lbf/in² (689.50 kN/m²) and note leakage. This must not exceed 1 1/2 g.p.h.
- (vi) Drain off excess fuel from valve.

13. BENCH TESTING PUMP AND MOTOR UNIT

Test fuels to be "Shell Super" 100 octane petrol, reference fluid SBP 62/68 or Fawley White Spirit 100 inhibited with 50 p.p.m. Santolene 'C'. Proceed to test as follows:

(a) Functional Tests

- (i) Connect a 13.5 volt supply to the motor and set the pump delivery pressure to 100 lbf/in² (689.50 kN/m²). Pump delivery and motor current should be as follows:

<i>Minimum Flow</i> (g.p.h.)	<i>Maximum Current</i> (Amps)
16 (100 octane)	5.0
15	5.2

- (ii) Connect an 8 volt supply to the motor and set pump delivery pressure to 100 lbf/in² (689.50 kN/m²). Pump delivery and motor current should be as follows:

<i>Minimum Flow</i> (g.p.h.)	<i>Maximum Current</i> (Amps)
Zero flow (100 octane)	6.0
Zero flow	6.3

- (iii) Check that pump will continue to run down to 6 volts at zero flow.

During the tests check unit for external leakage, particularly around joint faces of pump components and the seal leakage drain tube. See Figure 29 which shows test fuel comparison curves.

(Continued)

(b) Inhibiting

If tests have been carried out using inhibited Fawley White Spirit 700, no further inhibiting is necessary. If the test was made using petrol or SBP 62/68 fluid, it will be necessary to inhibit as follows. With a minimum head of 12 inches (304.8 mm) of clean filtered Shell Fusus 'A' or inhibited Fawley White Spirit 100, the pump must be run for one minute with the delivery pressure set at 100 lbf/in² (689.50 kN/m²). Drain off any excess oil from unit.

14. BENCH TESTING INJECTORS

To check injector opening pressure a test rig will be necessary on which the line pressure can be varied from 0–100 lbf/in² (0–689.50 kN/m²).

Calibration Fuel

Fawley White Spirit '100' plus 50 parts per million Santolene 'C' or Shell Calibrating Fluid 'C'.

The procedure is as follows:

- The injector should first be flow tested (flow rate 50–60 g.p.h.) at 100 lbf/in² (689.50 kN/m²). During this test the needle must vibrate freely off its seat, and the injector must produce an evenly distributed cone of fuel at an angle between 55°–65°.
- Flow injector with applied pressure of 100 lbf/in² (689.50 kN/m²), and gradually reduce to zero. Use air blast to remove fuel from nozzle tip. Increase applied pressure to 40 lbf/in² (275.80 kN/m²), and check time taken for a droplet to appear at injector tip. This should not be less than 60 seconds.
- Flow injector with applied pressure 100 lbf/in² (689.50 kN/m²), and gradually reduce pressure to zero. Use air blast to remove fuel from nozzle tip. Increase applied pressure and note pressure at which injector sprays, this should be between 45 and 55 lbf/in² (310.26–379.21 kN/m²).

15. HOW TO INHIBIT A CAR FITTED WITH LUCAS 'PI' EQUIPMENT

One cubic-centimetre (cc) of Santolene 'C' should be mixed with 30–50 cc of kerosene. (Because there is a small quantity of inhibitor, it must be mixed with a carrying agent before being admitted to the petrol tank).

Add the Santolene mixture to the petrol in the petrol tank. (The mixture is sufficient to inhibit 5 gallons (22.73 litres) of petrol.

The car should then be driven for approximately 5 miles to ensure the mixture is distributed throughout the 'PI' system.

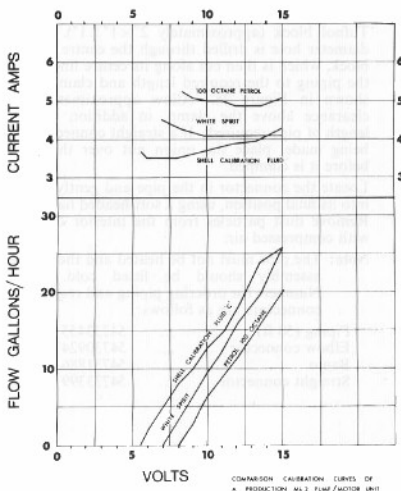

Fig. 29

16. QUICK CHECK OF FUEL FLOW RATE

Arrange for the fuel to flow into a container, graduated in cubic centimetres (cc), for a period of 8 seconds. Divide the quantity collected by 10, the result is gallons per hour.

$$\frac{\text{Quantity collected (cc)}}{10} = \text{galls. per hour}$$

17. EQUIVALENTS

1 cc is approx. equal to $\frac{1}{2}$ teaspoon or 20 drops.

1 gallon	= 4543.5 cc
1 pint	= 1.76 litres
1 litre	= 1000 cc or 1000 ml (milli-litres)

2.5 PETROL INJECTION SYSTEM (early cars)

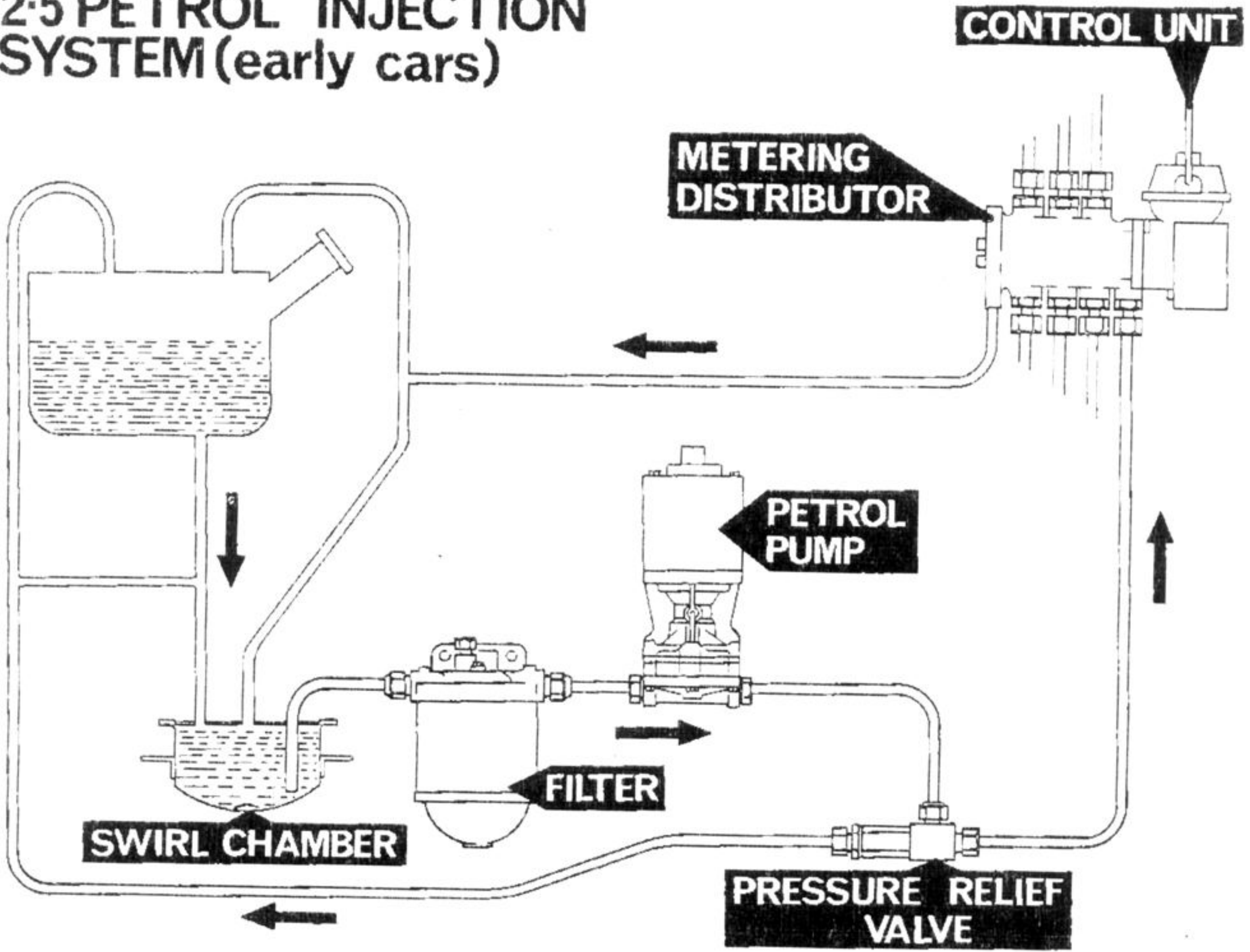

2.5 PETROL INJECTION SYSTEM (later cars)

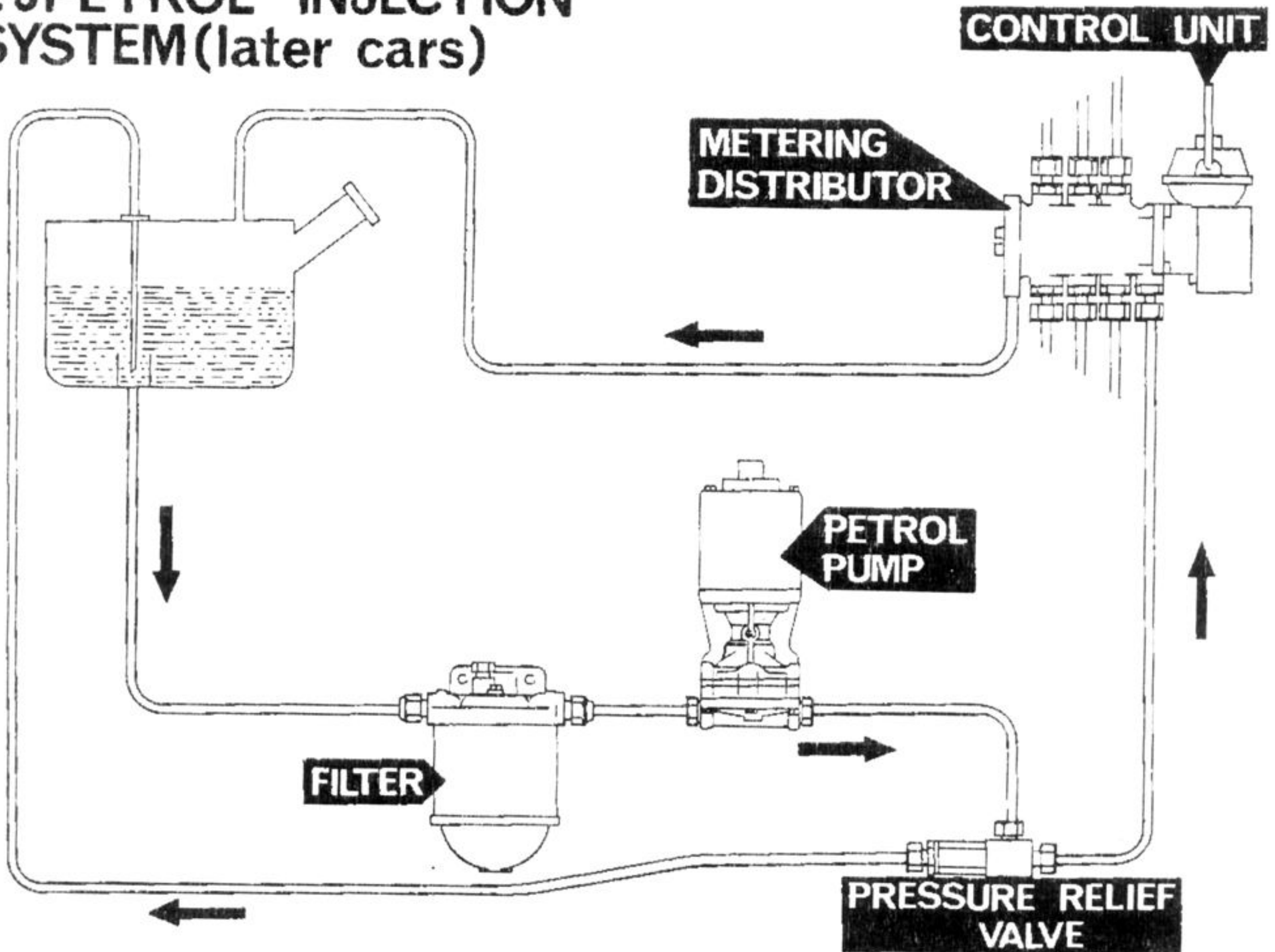

2.5 ESTATE CAR PETROL INJECTION SYSTEM

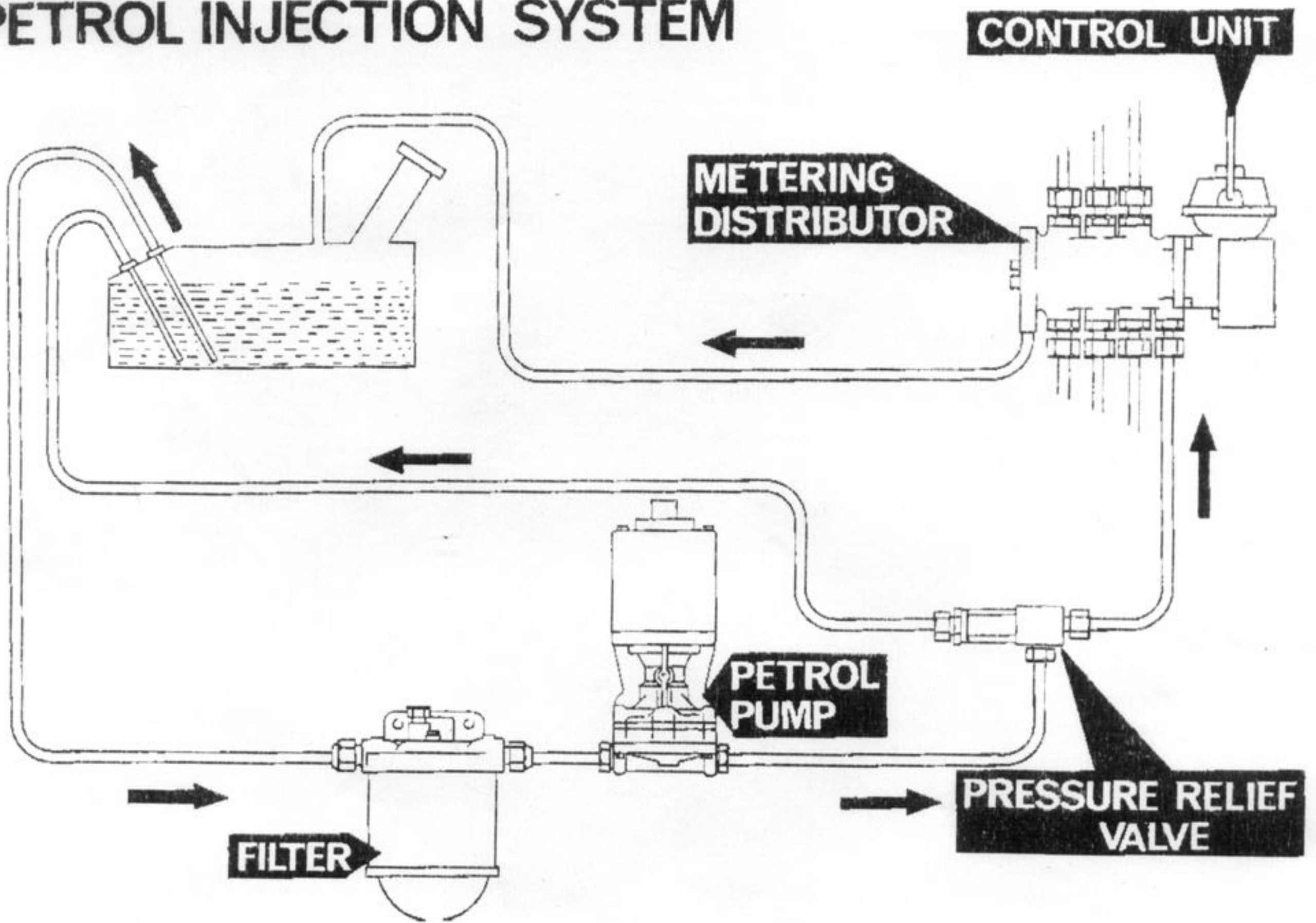

TR5 PETROL INJECTION SYSTEM

